



RODIX INC.
FEEDER CUBE®
VF Series
Wiring Diagram

VF-9CE
FEEDER CUBE®
Variable Frequency Control
OIL RESISTANT MODEL
IMPORTANT: APPLICATION NOTE

RUN JUMPER INPUT

A) LOW CURRENT SWITCH

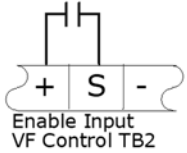

B) FEEDER BOWL/HOPPER INTERLOCK

Master VF Control TB2, Aux. OUTPUT

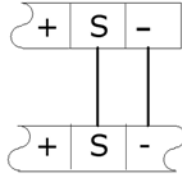

Subordinate VF Control TB2, Enable INPUT

C) LOW VOLTAGE INPUT SWITCHING

(Remove Run Jumper and apply DC Voltage from PLC)

5-30 VDC INPUT VOLTAGE OFF/ON CONTROL

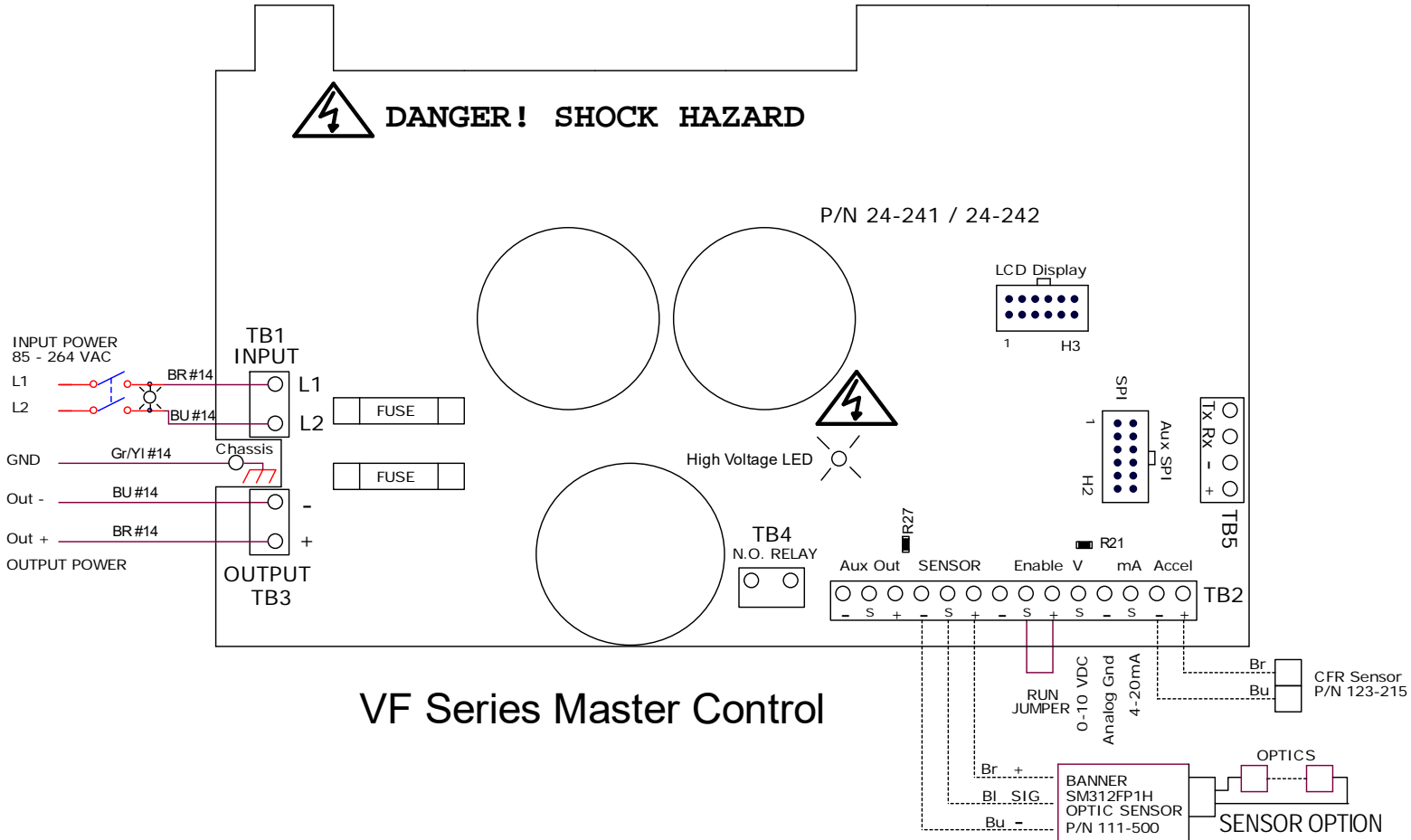
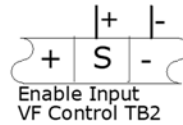



RODIX INC.
FEEDER CUBE®
VF Series
OIL RESISTANT



Model VF-9CE

P/N 121-000-0780* and 121-200-0780

Circuit Board P/N 24-242

*** includes CFR vibration sensor P/N 123-215**



Input Voltage: 85 - 264 VAC, 1Ø, 50/60 HZ.

Input Fuse Size: 5 AMPS

Output Voltage: 0 -120/240 VAC

Output Frequency: 5-180HZ.

Rated Output Current:

9 Amps at 120V or 4.5 Amps at 240V

© 2005, 2024 RODIX INC.

SET UP AND ADJUSTMENTS

Mounting

The control may be mounted vertically or horizontally, but the control will stay cooler when mounted vertically. Mount the control on a non-vibrating surface. The control is designed to withstand conditions equal to IP54.

Electrical Connections

Warning: Shock Hazard! Do not operate control with the cover open. Only skilled or instructed persons should open the enclosure. Disconnect power before opening the enclosure. The plug on the input power cord can be used as a disconnect.

Make all electrical connections prior to turning the control on. Once connections are made to the feeder control, any desired changes to the software settings can be made with the cover closed.

1. Part Sensor Input

(Photo-sensor or Proximity Switch)

Connect a three wire, current-sourcing (PNP) sensor to TB2 as shown on the enclosed wiring diagram. The sensor must be able to operate on 12VDC and be capable of switching at least 3.0 mA. See Parts Sensor Settings section for more operation information.

2. Run Jumper Input

A Run Jumper comes installed from the factory as shown on the enclosed wiring diagram.

If the run jumper input is to be controlled by a relay contact, switch, or other device, replace the factory-installed jumper (see TB2 of the wiring diagram) with the contact device. The contact must be able to switch 12VDC at 3.0 mA. The control will then run only when the contact is closed and the part sensor is calling for parts. The right column of the display shows the run status with "R= 1" or "R= 0."

If the run input will be controlled by a current sourcing PLC output, use the "Sig" and "-" terminals (see TB2 on the wiring diagram).

For the High/Low parts sensing mode, a second parts sensor (PNP type only) connects to the run input in place of the run jumper.

3. Auxiliary Output

The right column of the display shows the status of the Aux output, "A=1" or "A=0." The Feeder Bowl/Hopper Interlock "+" and "sig" (see TB2 on the wiring diagram) can be connected to a Rodix FC-40 All-Purpose Series control (TB2-11 & 12) when control of a bulk material hopper is needed. The control interlock will prevent the hopper from operating anytime the bowl is turned "OFF" or in "STAND BY" mode. The Interlock output is capable of switching 12 VDC at 85 mA. The Interlock output can also be used to drive a solid state relay that can operate auxiliary equipment such as air valves. See Figure 2 on the wiring diagram. One VF series control can be interlocked to another. The aux output of the master control connects to the run input of the subordinate.

A 1 Watt or 0.6 Watt 12VDC air solenoid or a relay can be driven by the Aux output. Note: a diode (1N4006) must be placed across the solenoid in the reverse polarity to adsorb the energy when the solenoid is de-energized. The "bar" side of the diode connects to TB2 "+" and the "solid colored" side connects to TB2 "SIG." Failure to use a diode in reverse polarity voids the warranty.

4. Internal Power Supply

At the rated line voltage, the line isolated power supply is capable of providing a combined total current of 150 mA at 12 VDC. The total current includes the parts sensor, auxiliary output accessories, and CFR sensor.

5. Power Connections

The control can operate on a power line from 85 to 264VAC. The plug can be connected to a standard North American outlet. Cut the plug end(s) off for 208 and 240VAC and make proper plug-in connections for the factory's power lines.

The variable frequency control is efficient because it recaptures the energy from the feeder coils every cycle.

6. External Speed Control Connections

The following methods of remote power level control can be utilized when desired:

- A. CFR sensor can maintain a constant feed rate. Attach the CFR sensor to terminals ACCEL “-“ (blue) and to ACCEL “+“ (brown). (Then update the software settings. Sections 11-A and 13-B)
- B. 4-20mA signal can be connected by bringing the positive signal wire to 4-20 “+“ and ground to 4-20 “-“. (Update software settings. Sect 11-B)
- C. 0-10VDC Analog input signal can be connected by bringing the positive signal wire to 0-10V “+“ and ground to 0-10 “-“. (Update the software settings. Section 11-C)

Software Adjustments

Once the electrical connections have been made, the control can be turned on. The software settings can be adjusted as desired through the control menu.

Display Messages

The normal operating display shows the status of the control with regard to input signals and control settings. See the Control Menu Layout page for display message details.

Navigating The Control Menu

The control uses four programming keys to program the control. The “I/O” key controls run, stop, and over-ride.

- A. The **ENTER** key allows entry to the menu and access to adjust each setting. Push and hold the enter key to enter the program mode. If the security feature has been enabled, enter the proper code. Once inside the menu, the enter key selects a menu item or a parameter to adjust. Any changes to the settings are saved at power-down.
- B. The **BACK** key moves the current menu location up one level higher than it was before. It is also used to get back to the normal operating display.
- C. The **Arrow Down** key allows the user to step down through the program menu or to decrease a setting.
- D. The **Arrow Up** key allows the user to step up through the program menu or to increase a setting.
- E. The “**I/O**” key allows the user to temporarily stop or to start the control’s operation. When the LCD status reads “Stop/Run,” hold the “I/O” key down for just over a second, and the control will start the over-ride operation. In over-ride mode the output turns on regardless of I/O connections and status. See the “Control Menu Layout” chart for the menu

structure. When in the menu mode and no keys are pressed for 1 minute, the display reverts to the normal operating display mode.

7. Amplitude Power Setting

The output power is controlled by the up and down arrow keys. The power setting can be adjusted with the keys unless the security feature lock has been selected. Once the proper security code has been entered, the power setting may be adjusted under the “Power” menu. Note: the power setting may not be above the maximum power setting or below the minimum power setting level. The amplitude power setting is displayed in the following manner: “A=50.0%.”

8. Limiting The Maximum Output Of Control

The “Max Amplitude” setting can be adjusted to keep a vibratory feeder from hammering or vibrating excessively when the control is turned up to full power. The maximum power setting can be found under the “Power” menu. It can be adjusted from 100.0% down to 40.0%.

Caution: it is recommended when using the CFR feature, that the Max output level of the control should be limited to prevent feeder coil from overheating. The amplitude could continue to increase if the system cannot get back to the desired vibration level.

9. Setting The Minimum Output of Control

The “Min Amplitude” setting can be adjusted to the desired low level of vibration. The minimum power setting can be found under the “Power” menu. It can be adjusted up from 0.0% to 95.0%. Note: the software does not allow the minimum level to be within 5.0 counts of the maximum level.

10. Setting The Soft-Start

The start-up of the control’s output can be adjusted to ramp up to the desired output level instead of starting abruptly. Soft-start keeps parts from falling off the tooling, reduces spring shock, and can eliminate hammering when the control turns ON. The soft start setting can be found under “Power Settings” menu. The soft start can be set from 0.0 to 10.0 seconds. When using the 2 speed operation, the soft start function is active during the low to high speed transition.

11. External Speed Control

The feeder control’s power level can be controlled by an external signal from a PLC, CFR sensor, or an analog source. The “External Speed Connections” section gives connection details.

- A. When the Constant Feed Rate (CFR) sensor is used, The “Amplitude Source” and “Frequency Mode” settings should be set to “Auto Track.” The control should display “Run/CFR” showing that the sensor is connected. Set the power setting to the desired feed rate. The control uses information from the CFR sensor to maintain a constant vibration level at the resonate frequency. See the CFR instructions page for more information.

Caution: it is recommended when using the CFR feature, that the Max output level of the control should be limited to prevent the feeder coil from overheating. The amplitude could continue to increase if the system cannot get back to the desired vibration level.

- B. 4-20mA signal from a PLC can be used to remotely vary the output of the control instead of the keypad. The “Amplitude Source” setting must be set to 4-20mA to enable it. After the 4-20mA feature is selected, the control will automatically turn ON whenever a 4-20mA signal is applied to the control (TB2 “+ 4-20” & “-“). When the 4-20mA signal has been removed, the amplitude setting resets to zero.
- C. 0-10VDC signal from a PLC can be used to remotely vary the output of the control instead of the keypad. The “Amplitude Source” setting must be set to 0-10VDC to enable it. After the 0-10VDC feature is selected, the control will automatically turn ON whenever a signal is applied to the control (TB2- “+0-10” & “-“). When the 0-10VDC signal has been removed, the amplitude setting resets to zero.
- D. When it is desirable to ignore the external speed control inputs, the “Manual” setting can be selected.

12. CFR Positive and Negative Gain

The CFR Positive and Negative Gain settings control the rate the feeder's vibration level is corrected by the control. When the vibration decreases below the set-point, the "CFR Positive Gain" sets the rate at which the output gets boosted to compensate for a vibration decrease. When the vibration increases, the "CFR Negative Gain" sets the rate at which the output gets lowered to compensate for a vibration increase. If either the CFR Positive or Negative gain is set too low, it will take longer than desired to get back to the original feed rate. If either gain is set too high, the control may over-shoot beyond the original feed rate. The CFR Positive and Negative Gain settings effect the control's operation when the CFR sensor is used, and the "Amplitude Control" is set to "Auto Track."

13. Current Limit Protection

The control has a coarse, adjustable over-current fault protection that trips when the output current is above the current limit setting. The current limit can be reduced to protect coils from overheating. Coils should never be too hot to touch. The VF-3 is rated 3A at 120V and 1.5A at 240V. The VF-9 is rated 9A at 120V and 4.5A at 240V. If an "Over Current" occurs, press the "1/0" key to restart the control.

14. Frequency Settings

The "Frequency" menu contains the portion of the menu that controls the frequency settings. The frequency can be adjusted from 5 to 180Hz. The spring/mass ratio of the vibratory bowl determines the natural vibrating (resonate) frequency of the bowl. The control's output frequency needs to be adjusted to match the natural frequency of the bowl. The control can be manually tuned or automatically tuned. The frequency setting is displayed as "F= 120.0Hz." The "Frequency Mode" setting selects either manual frequency adjustment or auto tracking frequency adjustment.

A. Manually finding the resonate frequency of the bowl is much like finding a station on the AM radio band. Set the amplitude to about 30%. Then adjust the frequency across its range. The bowl should be expected to vibrate the parts at more than one spot across the frequency range. The resonate frequency is the frequency with the most vibration. Once the best feeding frequency range has been found, fine tune the frequency for the best parts movement. To increase feeder stability for parts load fluctuations, adjust the frequency down by .2

or .3Hz so that the feeder becomes slightly over-tuned.

B. "Auto Scan" scans to locate the bowl's resonate frequency. Once auto tracking has found the resonate frequency, it can maintain the resonate frequency and amplitude of the feeder as the parts load changes. The CFR sensor is needed in order for auto tracking to operate, and "Auto Tracking" needs to be turned on under both "Amplitude Source" and "Frequency Mode" menus.

To show when frequency "Auto Tracking is enabled, the normal display menu will show a bold "F." When "=" is shown in bold, the control is locked onto the resonate frequency of the feeder.

The Minimum frequency limit can protect the feeder from feeding at a low frequency if a spring or weld breaks. The Min. or Max. frequency can block out undesirable frequencies during Auto Scan. To avoid coil damage and blown fuses during an Autotune scan, the Minimum frequency should only be adjusted below the 45Hz default when the vibratory feeder has been specifically designed for operation below 45Hz.

15. Resonate Threshold Level

The "Resonate Threshold Level" setting sets the minimum level of vibration that the control considers as a resonate condition during an Autoscan. The setting should be reduced if an "Auto Scan" cannot find the resonance frequency after two scan attempts. Adjustment is not normally needed.

16. Auto Track Dead Band

The "Auto Track Dead Band" setting controls how far the resonant frequency of the vibratory feeder can deviate before the output frequency of the control is adjusted to follow it. Decreasing the setting narrows the range, and increasing the setting makes the dead band range larger before a reaction takes place. This setting normally doesn't need to be changed.

17. Setting The Time Delays

The ON and OFF parts-sensor time-delays are set independently for a period of 0-20 seconds. The time delay settings can be adjusted to provide the best individual response for the feeder. The time delays can be found under the timer settings menu. The flashing "=" blinks every quarter second to show when either the ON and Off delay timer is running.

18. Parts Sensor Settings

The "I/O Interface" menu contains the portion of the menu that controls the parts sensor type and polarity. The control works with a PNP sensor. The control's logic comes preset to "inverted" sensor polarity. Set the sensor polarity to either "Normal" (through beam) or "Inverted" (proximity or retro-reflective).

19. Run Mode Settings

The "I/O Interface" menu contains the portion of the menu that controls the run mode and empty bowl logic.

A. The control comes preset for normal on/off parts sensor operation. The following can be chosen:

1) The "Constant On" feature can be used to keep the bowl running while the Aux output switches power to a device (air valve, SSR, or relay).

2) The "2-Speed" feature allows the bowl to keep some vibration going to either trickle parts for weigh counting or to cut down the time to full speed when a high feed rate is needed. The parts sensor switches between high and low speed settings. Low speed is set by "Min Amplitude."

3) The "high/low" function maintains the parts level between two parts sensors on the track. The second sensor (PNP) gets installed in place of the run jumper.

B. The control comes preset with the "empty bowl timer" (or parts jam timer) disabled. Once enabled, the bowl will stop feeding when parts have not passed the sensor for the set time. The empty bowl timer can be adjusted from 5 to 255 seconds under the "timer settings" menu. Press the "1/0" key or toggle the parts sensor to restart the control. The auxiliary output can be set up to turn on a signaling device. See the section that describes the auxiliary output for more details.

20. Run Input Settings

The "Run Input" menu controls whether the control follows (normal) or ignores (disable) Run Input signal. Set to follow or ignore the interlock signal from a master control board when applicable.

21. Auxiliary Output Settings

The “Aux Output Mode” menu contains the menu that controls the auxiliary output (Aux Out) operation.

- A. The factory-default “Normal” setting allows the auxiliary output to turn on and off with the output of the feeder.
- B. The auxiliary output can be set to have its signal inverted from the output of the feeder. Set the “Aux Out” parameter to “Invert” to activate it.
- C. The auxiliary output can be set so that the alarm signal can indicate when the “Empty Bowl” timer has timed out. Set the “Aux Out” parameter to “Alarm” to activate it.
- D. The auxiliary output can be set so that the alarm signal can be inverted when the “Empty Bowl” timer has timed out. Set the “Aux Out” parameter to “Inv Al” to activate it.
- E. The auxiliary output can be set so that an air solenoid can be activated 1 second before feeding begins and continue for 4 seconds after feeding ends. This feature is helpful for parts orientation. Set the “Aux Out” parameter to “Air Jet” to activate this feature.

21. Diagnostics

- A. The first menu item under the diagnostic menu shows the software revision level.
- B. The next four items under the software revision level show certain software registers that may be helpful to Rodix staff while troubleshooting over the phone.

22. Security Settings

The “Security” menu contains the portion of the menu that controls access to the program menu settings. When enabled, the security code is a number from 0.0 to 99.9. The preset code is 0.0. It may be changed.

- A. The control comes with the security setting “Unlocked” so the control can be set up. The amplitude can be adjusted from the normal operating display. Press and hold “Enter” to enter the program menu and adjust the software settings.
- B. The amplitude only (Ampl. Only) adjustment allows operators to adjust the amplitude through the normal operating display, but not get to the program menu settings without the security code.
- C. The “Lock” setting locks the control from any adjustment without the use of the security code. If the security code has been forgotten, enter the security code #13.5, then press “Enter”. Once in the programming menu be sure to set the security code.

23. Default Memory

Occasionally it is nice to get back to a known setting. Once a feed system has been set up properly, the setting should be manually saved into the “Save Settings1” memory. If an operator disturbs the settings, the “Restore Settings1” feature can restore the control to a known good set up. When different parts are used on the same feed system, two other memory locations called “Save Setting2” and “Save Settings3” can be used for other parts. Operators can recall settings 1, 2 or 3 based on the part being used. The “Factory Reset” selection will put the original factory settings into the memory.

24. Language

The run display and programming menus can be set to display in English, Spanish (Español), French (Français), or German (Deutsch).

25. CFR Set Point

The CFR set point sets the amplitude vibration level that the control regulates to. The VF Series control adjusts the amplitude automatically to match the CFR set point. The CFR set point can be adjusted by the depression of the “UP” and “DOWN” arrows keys. Holding an arrow key down will adjust the amplitude setting instead of the CFR set point. The CFR set point can also be controlled by a 4-20mA signal.

The CFR set point only appears on the display when the “Amplitude Source” menu under power settings is set to “Auto Track” and the CFR sensor is attached.

26. Fault Messages

The VF control has error and warning messages that relate to “Over-Amps”, “Over-Temp” and Bowl out of parts timers. To clear the message or fault, press the “1/0” button twice.

27. Spare Parts

Description	Q	Rodix P/N	MFG & P/N
Fuse 5 Amps	2	106-0066	Schurter 0001.1011
Switch Boot	1	104-0107	Hex Seal C1131/26-M12-.75
Power Switch	1	104-0106	Apem 641H/2

WARNING:

Fuses should be replaced with a “Fast Acting” type or equivalent of manufacturer’s original value.

Mounting this control on a vibrating surface will void the warranty.

Warranty

Rodix Control Products are Warranted to be free from defects in material and workmanship under normal use for a period of two years from date of shipment. For the full description of the warranty, terms, and software license, please contact the factory.

For assistance installing or operating your Rodix Feeder Cube® please call the factory or visit our web site. Technical help is available to answer your questions and email any needed information. To return a control for IN or OUT of warranty service, please ship it prepaid to:

Rodix Inc., ATTN: Repair Department

If under warranty, Rodix will repair or replace your control at no charge; If out of warranty, we will repair it and you will be billed for the repair charges (Time and Material) plus the return freight. Quotes for repairs are available upon request. A brief note describing the symptoms helps our technicians address the issue.

Feeder Cube® is a registered TM of Rodix Inc.

Banner® is a registered Trademark of Banner Engineering Corp, 9714 10th Ave, Minneapolis, MN 55441

RODIX, INC.

Toll Free (800) 562-1868

E-mail custserve@rodix.com

www.rodix.com

VF-9 Dimensions

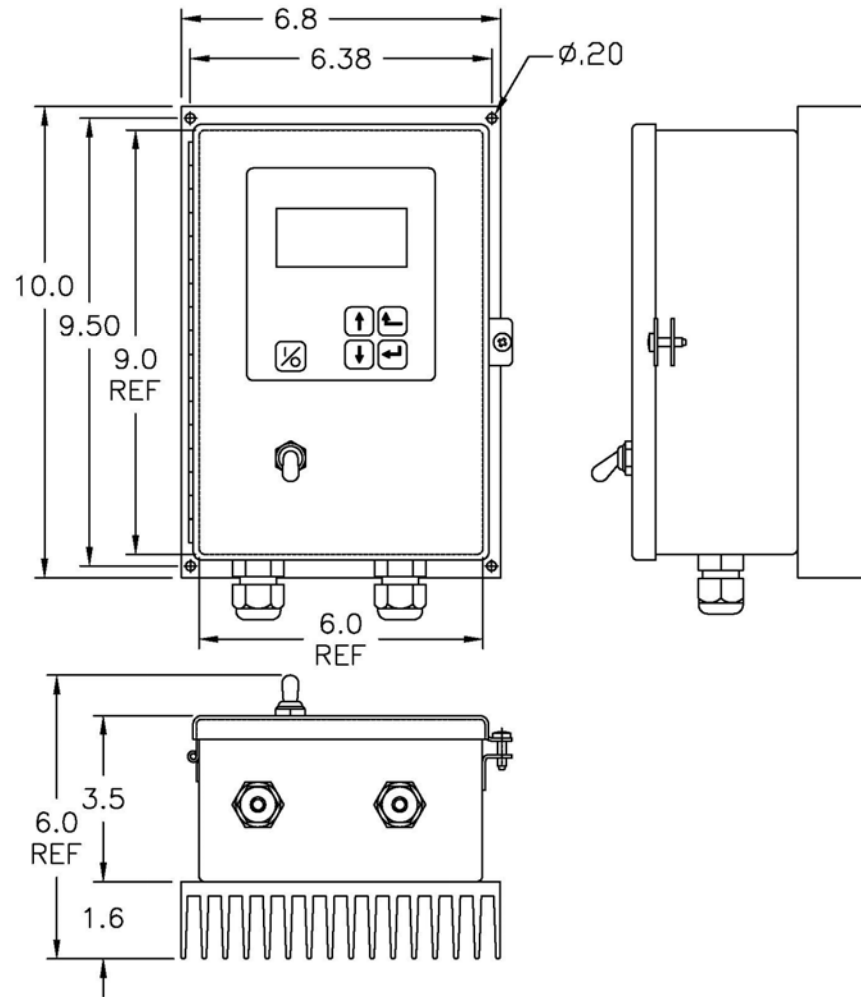

Control Menu Layout for VF Series

Normal Operation Display		
Press and hold 'Enter' key to enter the program menu or get to the security menu. Then use the "Enter" key to move right from Main Menu to Sub Menu to the Adjustable Setting. Use the "Back" key to move left.		
Main Menu	Sub Menu	Adjustable Setting
→ Power Settings	Amplitude Max Amplitude Min Amplitude Soft Start Time Amplitude Source Amplitude Set-Point CFR Positive Gain CFR Negative Gain Current Limit	[0.0 to 100.0] % [100.0 to 20.0] % [0.0 to 95.0] % [0.0 to 10.0] Seconds (0.5 Default) [Auto Tracking Manual, 0-10V, 4-20mA] [0.0 to 1250] vibration level [7 Default] [12 Default] [9.5 VF-9, (3.5 VF-3), (12.5, VF-12), (18.0, VF-18) Default] Amps
→ Frequency Settings	Frequency Max Frequency Min Frequency Frequency Mode Auto Scan Resonate Threshold Level Auto Track Dead Band	[5.0 to 180.0] Hz (60.0 Hertz Default) [15.0 to 180.0] Hz (140.0 Hertz Default) [5.0 to 170.0] Hz (45.0 Hertz Default) [Auto Tracking , Manual] [Press ENTER to perform an automatic frequency scan] [15.0 Default] [15 Default]
→ Timer Settings	On Delay Off Delay Empty Bowl Timer	[0.0 to 20.0] Seconds (0.5 Default) [0.0 to 20.0] Seconds (0.5 Default) [5 to 255] Seconds (10 Default)
→ I/O Interface	Sensor Polarity Run Mode Run Input Empty Bowl Aux Output Mode	[Inverted , Normal] [Normal , Always On, 2-Speed, High/Low] [Normal , Disable] Run Input can be ignored. [Normal , Stop] [Normal , Inverted, Alarm, Inv Alarm, Air Jet]
→ Security	Keypad Lock Security Code	[Unlocked , Amplitude Only, Locked] [00.0 to 99.9]
→ Language	Pick Language	[English, Spanish, French, German, Czech, Dutch, Italian, Polish, Portuguese, Swedish, Turkish]
→ Diagnostics	Board/Load Current Accelerometer AC Volts Analog 4-20 mA, 0-10 V Temp, Temp, PS Volts Software, Software Vers.	[data, data] Board, Amps [data] signal amplitude [data] Volts [data, data] mA, Volts [data], [data] °C, [data] Volts → Self Test1/factory reset (factory test only) [data] Power, [data] Display
→ Defaults	Restore Settings 1 Restore Settings 2 Restore Settings 3 Save Settings 1 Save Settings 2 Save Settings 3 Factory Reset	['Enter' Restores User Settings 1] ['Enter' Restores User Settings 2] ['Enter' Restores User Settings 3] ['Enter' Saves User Settings 1] ['Enter' Saves User Settings 2] ['Enter' Saves User Settings 3] ['Enter' Resets Control to Factory Default Settings (Shown in bold)]

Normal Display Message Priority:

Status Line Message	→	Run/CFR	R=1	←	Run Input: 1= on /closed & 0= off/open
CFR Set Point	→	CFR=024.5	S=1	←	Sensor Input: 1= on /closed & 0= off/open
Amplitude	→	A= 40.0%	O=1	←	Output to vibratory feeder: 1= on & 0= off
Frequency	→	F= 60.0Hz	A=1	←	Aux Output: 1= on & 0= off

The **normal operating display** shows the status of the control with regard to input signals and control settings. They are listed from highest to lowest in priority. The highest priority message takes precedence over the other messages.

Stop/Run - The 1/0 button has been pushed to disable control operation.

Override - The 1/0 button has been pushed and held so the control feeds while ignoring the "Sensor" or "Run" inputs.

Run Input - The run jumper has not been made.

Parts Sens - The parts sensor and control logic is telling the control to stay off.

Empty/jam - Empty bowl timer is timed out because parts did not pass by the parts sensor to reset the timer. Press 1/0

Analog - An external signal is in control of the speed input.

Low - Low Speed used when 2 speed has been selected and the sensor is not made.

Zero Speed - The output is off because the output is set to 0.0%.

Run - The feeder is running normally.

Run/CFR - Constant Feed Rate sensor is regulating the feed rate (Autotune®).

Steps to Interlock Two VF Series Controls together

1. Remove the run jumper from TB2 "Enable" terminals of the subordinate control.
2. Add a wire from the "Aux Out S" terminal of the master control to the "Enable S" terminal of the subordinate control.
3. Add a wire from "Aux Out -" terminal of the master control to "Enable -" terminal of the subordinate control.

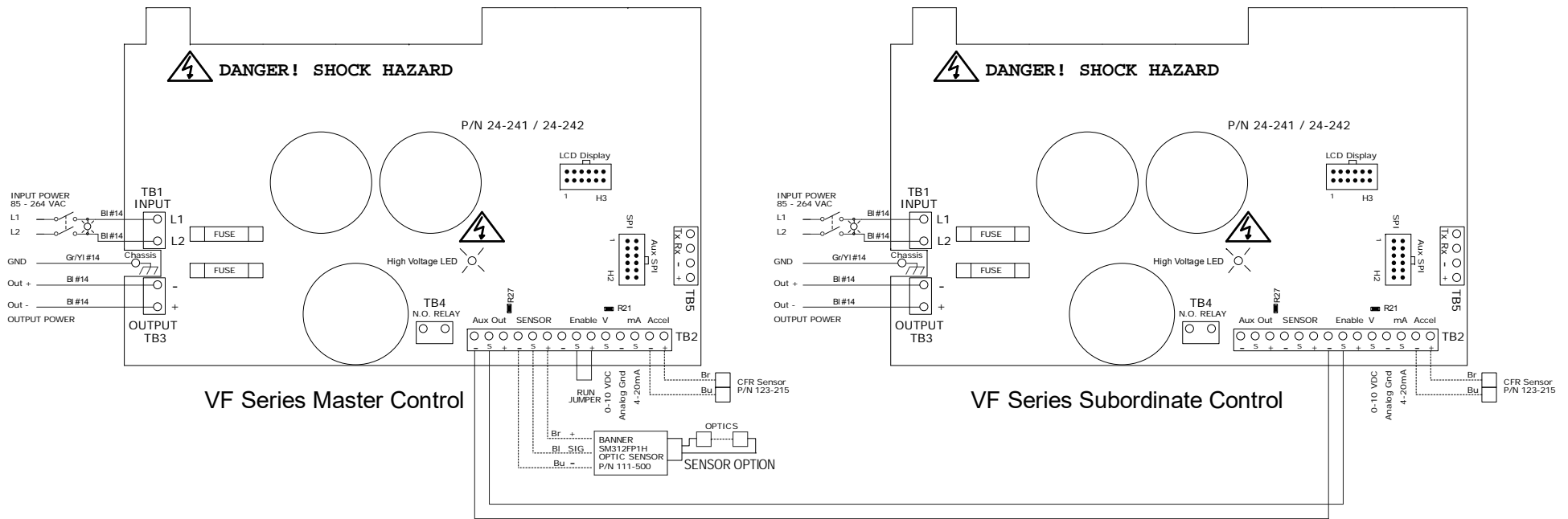

Steps to Interlock an FC-40 Plus Series to a VF Series Control

1. Add a wire from the "Aux Out S" terminal of the VF master control to TB2-12 of the subordinate control.
2. Add a wire from "Aux Out -" terminal of the VF master control to TB2-11 of the subordinate control.
3. Move the run jumper on the subordinate control from TB2-6 & TB2-7 to TB2-5 & TB2-6.

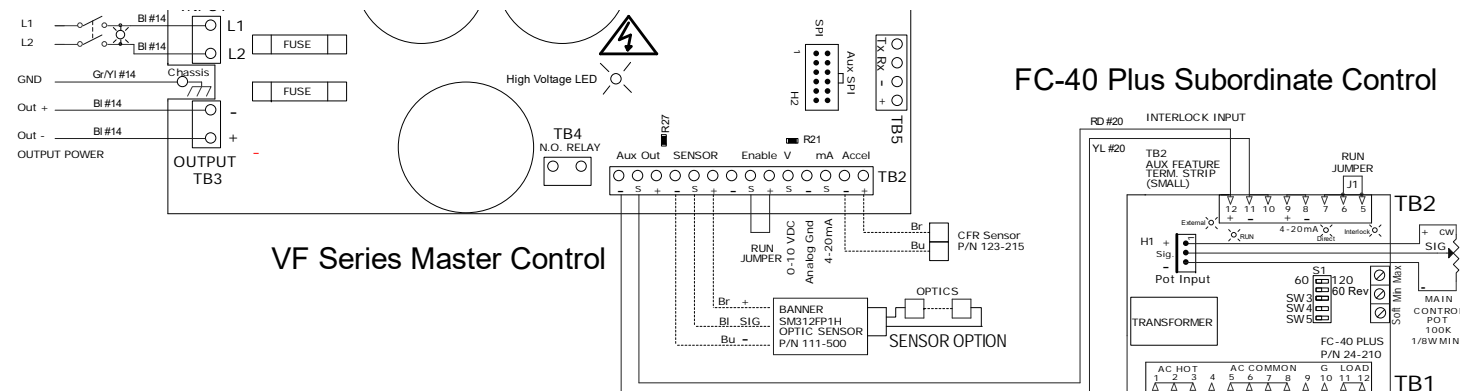

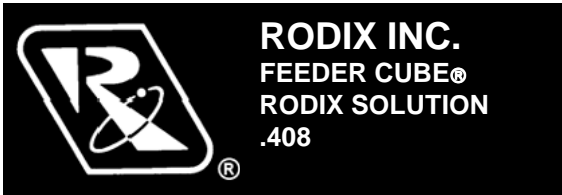

RODIX SOLUTION

Good wiring practices for avoiding electrical noise problems.

Rodix controls have been designed with a high degree of immunity to electrical noise; however, depending on the control installation, electrical noise can cause problems. These problems occur in less than 1% of the product installations. Most electrical noise problems can be avoided by following some simple guidelines. Good wiring practices need to be used to prevent electrical noise from interfering with your control's operation. Another name for electrical noise is Electro-Magnetic Interference (EMI).

Symptoms of Electrical Noise

The symptoms of electrical noise would appear as follows: a brief pause or a brief "bump" in the vibratory feeder's output that the control automatically recovers from. In rare cases the control will either stop operating or run continuously at full power in 120 pulse mode until the power switch is slowly cycled OFF and ON.

Sources of Electrical Noise

Electrical noise is generated by devices like relay coils, solenoid valves, contactors, servo motors, and variable

frequency inverter drives. The electrical noise is then transferred to another device by one of three ways. The noise could be conducted through the power wires, or capacitively coupled from wire to adjacent wire, or it is transmitted from the wires of a nearby noise source.

Solutions for Electrical Noise

1. Use shielded wires for all I/O (Input / Output) signals. The I/O signals may include: 4-20mA input, Run input, Sensor input, 0-5VDC input, Interlock input or AUX output. The shield "drain" wire should be tied to the chassis in the Rodix control. The drain wire should be kept shorter than 2". Please see the enclosed picture.

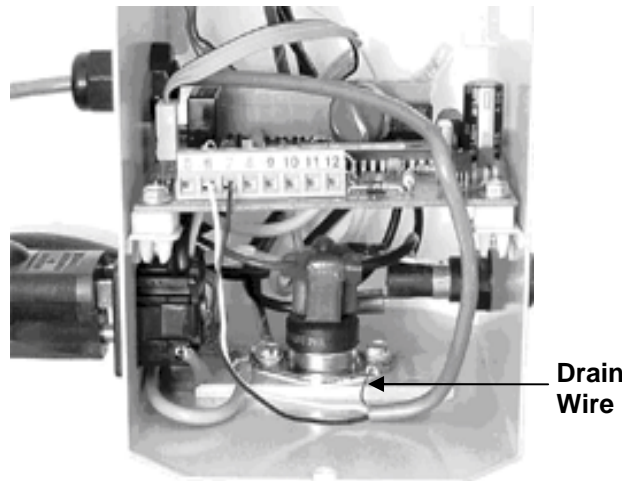

Example of a "drain" wire termination

2. Never run I/O signal wires in the same conduit or raceway as AC power lines such as wires to motors, solenoids, heaters, welders and Rodix controls, etc.

3. I/O wires within an enclosure should be routed as far away as possible from relays, solenoids, transformers, power wiring and other noisy equipment. Keep the I/O signal wires separate from the control's input and output power wiring. Secure the wires in place.

4. Whenever relays or solenoid valves are used, install a Snubber on them to reduce electrical noise. Use a diode on a DC coil. Use a RC Snubber on an AC coil.

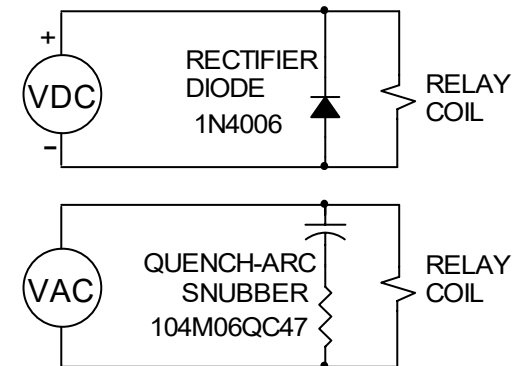

5. In extremely high EMI environments, Power Line Filters and ferrite beads can be effective. Install ferrite beads on I/O signal wires as close as possible to the circuit board terminal strip. Loop the wire through the bead several times or use several beads on each wire for additional protection.

RODIX, INC.

2316 23rd Avenue, Rockford, IL 61104
 Toll Free (800) 562-1868, FAX (815) 316-4701
 E-mail custserve@rodix.com
www.rodix.com

Declaration of Incorporation

We hereby declare that the following machinery is intended to be incorporated into other machinery, and must not be put into service until the relevant machinery into which it is to be incorporated has been declared in conformity with the essential requirements of the Machinery Directive, 2006/42/EC, and requirements of the Low Voltage Directive, 2006/95/EC.

Safety of Machinery: EN 60204-1: 2006
Machine Safety was evaluated by Rodix Inc.

Supplementary Information: Electromagnetic Compatibility Record 2011-068B
EMC testing was performed by:
L.F. Research, 12790 Route 76, Poplar Grove, IL 61065, USA

Testing was performed to satisfy the Electromagnetic Compatibility (EMC) requirements for Industrial Equipment. The testing is used to support compliance with the European EMC Directive, 2004/108/EC. The EMC immunity and emissions of the equipment were assessed per:

EN 61000-6-2 Electromagnetic compatibility, Generic standards - Immunity for industrial environments
EN 55011: 2007 Industrial, scientific and medical radio-frequency equipment. Electromagnetic disturbance characteristics. Limits and methods of measurement

Machine Description: Vibratory Feeder Control

Makes: VF-3CE, VF-9CE

Types:

121-000-0780, 121-000-0781

121-200-0780, 121-200-0781

Manufactured by: Rodix Inc.

A technical construction file for this equipment is retained at the following address:

2316 23rd Avenue, Rockford, Illinois 61104, USA

Date: 4/8/2013
Title: Vice President

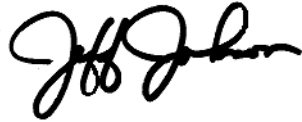
Signature: 
Name: Jeff Johnson